

## Refrigeration & Freezer Temperature Sensor

### Protected against moisture!

- ◆ Ideal for refrigerated rooms, freezers, cold storage facilities, laboratories — anywhere an accurate, rugged, weatherproof temperature sensor is needed
- ◆ 100 Ω platinum RTD probe is constructed of 316 stainless steel to be resistant to most chemicals, including ammonia. Operates to -452°F (-269°C)
- ◆ 4-20 mA transmitter is epoxy potted to protect circuitry from condensation and ice. Operates in ambient temperatures down to -13°F (-25°C)
- ◆ Transmitter is match calibrated to RTD for 0.75% system accuracy; *free* NIST certificate
- ◆ Enclosure is gasketed and moisture resistant
- ◆ RTD probe is available in lengths ranging from 2 inches to 48 inches, and the probe can be center-mounted for through-the-wall installation, or end-mounted for flush-to-the-wall mounting

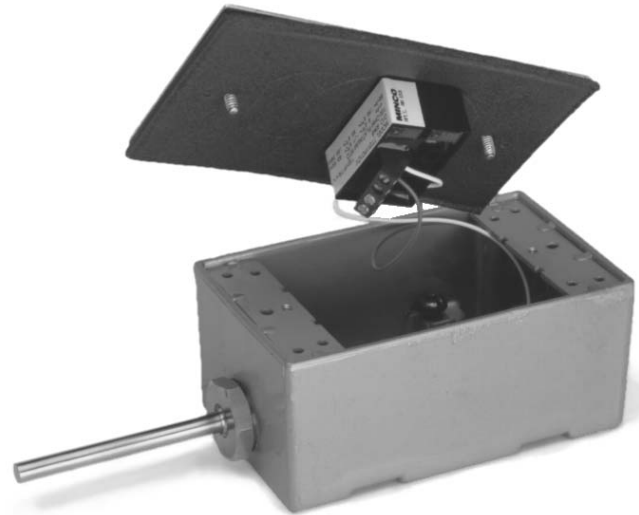

(End-mounted)

### Specifications

#### Operating Temperature Range:

Probe: -452 to 500°F (-269 to 260°C).  
Transmitter: -13 to 185°F (-25 to 85°C).

**RTD Probe:** 100 Ω Platinum, 0.00385 TCR.

**Transmitter:** 4-20 mA output, 8.5 to 35 VDC loop powered.

#### Dimensions in inches:

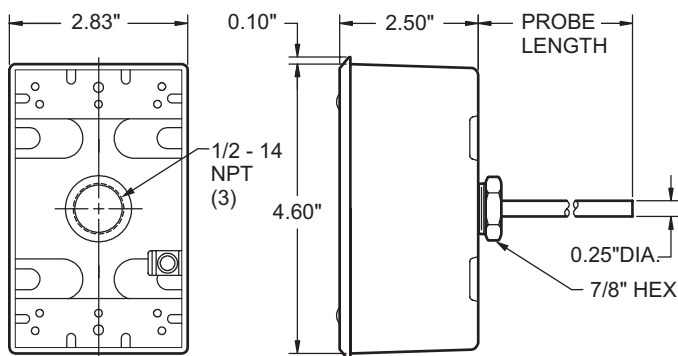

(Center-mounted)

### How to order

AS100279	<b>Assembly number</b>
PD	<b>100 Ω platinum RTD</b>
67	<b>Probe length:</b> Specify in 0.1" increments Ex: 67 = 6.7 inches
M	<b>Code for transmitter span:</b> M = -58 to 122°F (-50 to 50°C) AD = -40 to 120°F (-40 to 48.9°C) DN = -22 to 122°F (-30 to 50°C) S = 0 to 100°F (-18 to 37.8°C) BY = 14 to 104°F (-10 to 40°C) Other spans are available.
AS100279PD67M ← Sample part number	

**Need more information? Call our HVAC/R specialist at 763-586-2939.**

**MINCO**  
ISO 9001

#### Minco Products, Inc. (Main Office)

7300 Commerce Lane  
Minneapolis, MN 55432-3177  
U.S.A.

Tel: 1-763-571-3121  
Fax: 1-763-571-0927

Stock order desk:  
Tel: 1-763-571-3123  
Fax: 1-763-571-9142



Internet:  
sales@minco.com  
www.minco.com

#### Minco S.A.

Usine et Service  
Commercial, Z.I.  
09310 Aston, France  
Tel: (33) 5 61 03 24 01  
Fax: (33) 5 61 03 24 09

#### Minco EC

Hirzenstrasse 2  
CH-9244 Niederuzwil  
Switzerland  
Tel: (41) 71 952 79 89  
Fax: (41) 71 952 79 90